

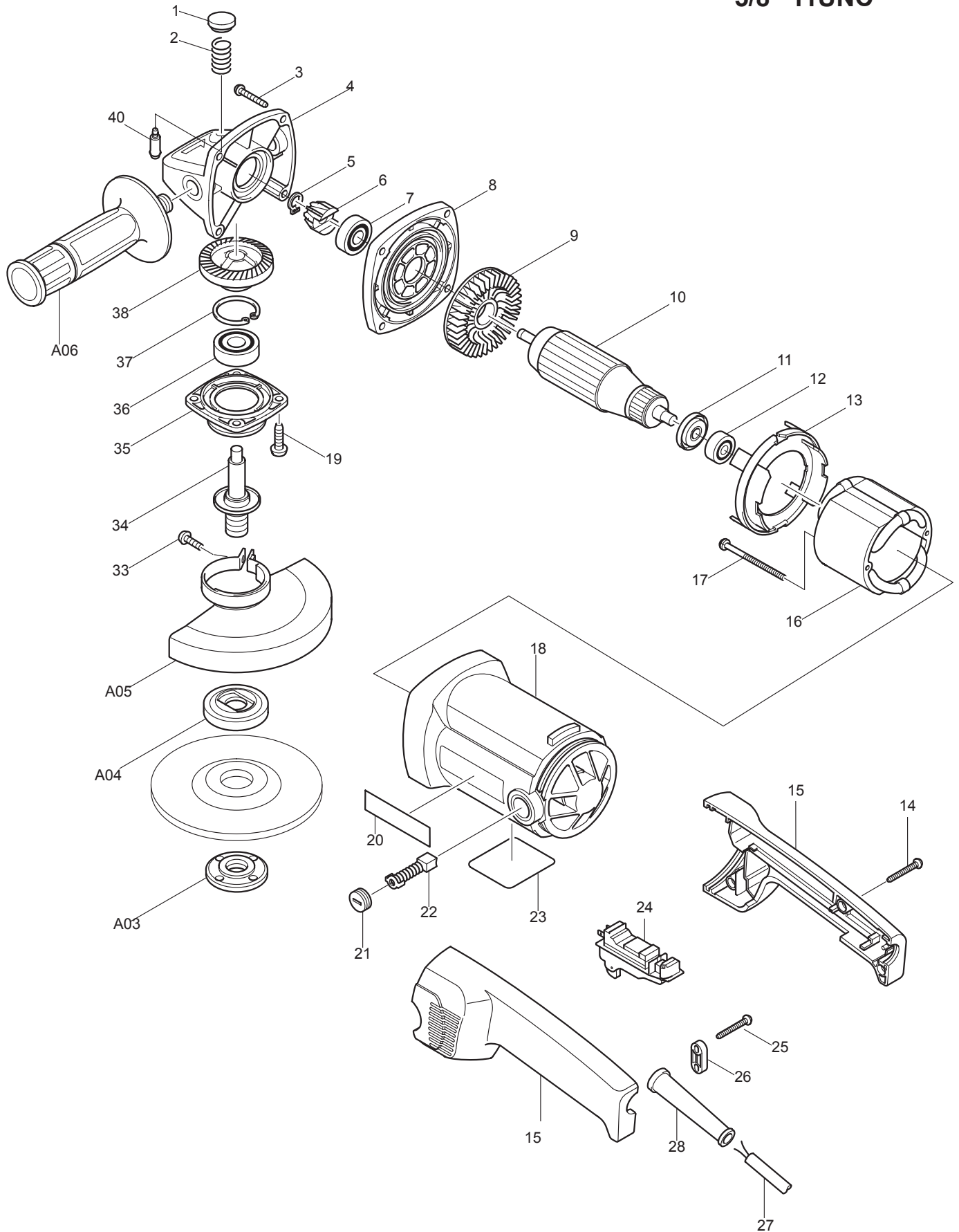

02 - 2010
9016DB / 9016DBZ
6" GRINDER AC/DC
5/8" 11UNC



Item No.	Type	Sub	Part No.	Description (* see Service Changes on the bottom)	Qty	Unit
1			416449-8	PIN CAP	1	PC.
2			233089-5	COMPRESSION SPRING 12	1	PC.
3			266173-1	TAPPING SCREW 5X30	4	PC.
4			153374-9	* GEAR HOUSING COM. (OLD# 159995-5 - N/L/A)	1	PC.
5			961003-8	RETAINING RING S-7	1	PC.
6			226756-9	SPIRAL BEVEL GEAR 11	1	PC.
7			211131-2	BALL BEARING 6001DDW	1	PC.
8			317323-2	* GEAR HOUSING COVER (OLD# 316992-6 - N/L/A)	1	PC.
9			240010-7	FAN 70	1	PC.
10			516331-2	ARMATURE ASS'Y 115V	1	PC.
		INC.		Item No. 9,11,12		
11			681644-1	INSULATION WASHER	1	PC.
12			210005-4	BALL BEARING 608DDW	1	PC.
13			416448-0	BAFFLE PLATE	1	PC.
14			265995-6	TAPPING SCREW 4X18	4	PC.
15			183274-9	* HANDLE SET (F/ 9016DB)	1	SET
			183010-3	HANDLE SET (F/ 9016DBZ)	1	SET
16			522846-9	* FIELD ASS'Y 115V	1	PC.
		INC.	654020-2	RING TERMINAL	2	PC.
		INC.	654501-6	CONNECTOR P-1.25	2	PC.
17			266029-8	TAPPING SCREW 5X65	2	PC.
18			183159-9	* MOTOR HOUSING (OLD# 159996-3 - N/L/A)	1	PC.
		INC.	643708-9	BRUSH HOLDER 5-11	2	PC.
		INC.		Item No. 20	0	
19	1		266027-2	* TAPPING SCREW CT5X16	4	PC.
	2		265096-0	* PAN HEAD SCREW M5X16	4	PC.
20			819001-5	MAKITA LABEL	2	PC.
21	1		643750-0	BRUSH HOLDER CAP 7-11	2	PC.
	2		643515-0	HOLDER CAP 7-11	2	PC.
22	1		191963-2	CARBON BRUSH CB-303 2PC/SET (W/O ORIGIN)	1	SET
	2		194996-6	CARBON BRUSH CB-303 2PC/SET (W/ ORIGIN)	1	SET
23			866512-1	NAME PLATE 9016DB	1	PC.
24			651166-5	* SWITCH (AC/DC) (F/ 9016DB)	1	PC.
			651128-3	* SWITCH (AC/DC) (F/ 9016DBZ)	1	PC.
25			265995-6	TAPPING SCREW 4X18	2	PC.
26			687063-9	CORD CLAMP	1	PC.
27			664265-4	CORD W/PLUG 2P-16-2.5M,SJ	1	PC.
28			682505-8	CORD GUARD 10-90	1	PC.
33			251391-4	PAN HEAD SCREW M5X16	1	PC.
34			152573-0	SPINDLE COMPLETE	1	PC.
		INC.	344347-5	LABYRINTH RING	1	PC.
35			316991-8	BEARING BOX	1	PC.
36			211129-9	BALL BEARING 6201DDW	1	PC.
37			962151-6	RETAINING RING R-32	1	PC.
38			226754-3	SPIRAL BEVEL GEAR 35	1	PC.
40			256446-0	PIN 6	1	PC.
41			262086-4	* RUBBER RING 29 (Added)	1	PC.
42			442126-6	* GASKET (Added)	1	PC.
43			163434-9	* SWITCH LEVER COMPLETE (F/ 9016DB) (Added)	1	PC.
44			417313-6	* SWITCH BASE (F/ 9016DB) (Added)	1	PC.
100			652039-5	* + BINDING HEAD SCREW M3.5X6.8 (F/ 9016DB)	4	PC.
			652014-1	P.H. SCREW M4X8 (F/ 9016DBZ)	4	PC.
101			654037-5	* INSULATED TERMINAL RBV1.25-3.5 (F/9016DB)	4	PC.
			654002-4	TERMINAL 1.25-M4 (F/ 9016DBZ)	4	PC.
			846304-4	CARTON F/9016DBZ	1	PC.

Item No.	Type	Sub	Part No.	Description (* see Service Changes on the bottom)	Qty	Unit
ACCESSORIES			- See Catalogue or visit www.makita.ca for optional accessory -			
A01			782412-6	LOCK NUT WRENCH 28	1	PC.
A02	1		A-80846	6" D.C.W. GRIT 36	1	PC.
	2		A-95978-25	6" D.C.G.W WA36N 25/PK	1	PC.
	Opt.		-----	DEPRESSED CENTER GRINDING WHEELS		
A03	1		224509-0	LOCK NUT 5/8-40	1	PC.
	2		224568-4	LOCK NUT 5/8-45	1	PC.
	Opt.		224574-9	LOCK NUT 5/8-48 (FOR CUT-OFF)	1	PC.
A04			224361-6	INNER FLANGE 82	1	PC.
	Opt.1		224378-9	INNER FLANGE 45 (FOR CUT-OFF)	1	PC.
	Opt.2		224390-9	INNER FLANGE 48 (FOR CUT-OFF)	1	PC.
A05	1		165213-1	WHEEL COVER	1	PC.
	2		134961-3	5" WHEEL COVER ASS'Y(D.C.W)	1	PC.
		INC.		Item No. 33		
A06			152492-0	GRIP 36 COMPLETE	1	PC.
A07			165744-0	CUT-OFF WHEEL GUARD F/6"	1	PC.
A08			193048-0	SANDING LOCK NUT 5/8-48	1	PC.
A09			743016-9	RUBBER PAD 125 F/6"	1	PC.

SERVICE CHANGES

1. Changes on Tapping Screw for securing Bearing Box to Gear Housing

Item No.	Description	Type 1	Type 2
4	Gear Housing Com.	159995-5	153374-9
19	Screw	266027-2 (Tapping CT 5x16)	265096-0 (P.H. Screw M5x16)
	Serial No. 9016DB	~ 9209E	9210E ~
	9016DBZ has Type2 from initial production		

Above parts are completely interchangeable as a set.

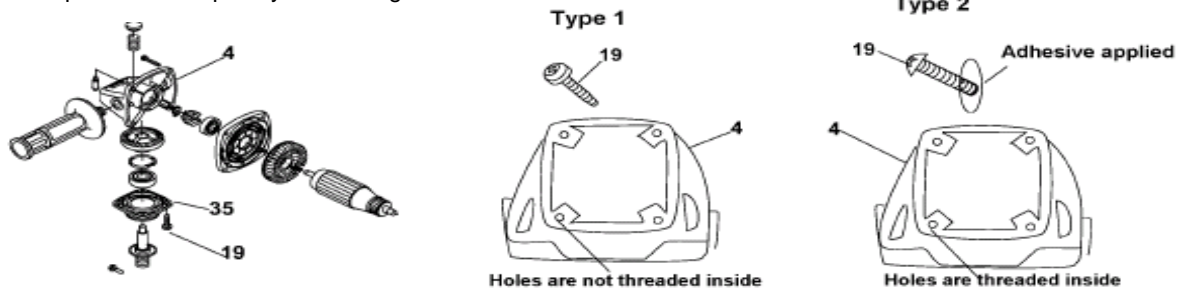

2. Changes on Gear Housing and Addition of Rubber Ring

Item No.	Description	Type 1	Type 2
8	Gear Housing Cover	316992-6	317323-2
41	Rubber Ring 29	-----	262086-4
42	Gasket	-----	442126-6
	Serial No. 9016DB	~ 4281E	4282E ~
	9016DBZ has Type2 from initial production		

Above parts are completely interchangeable as a set.

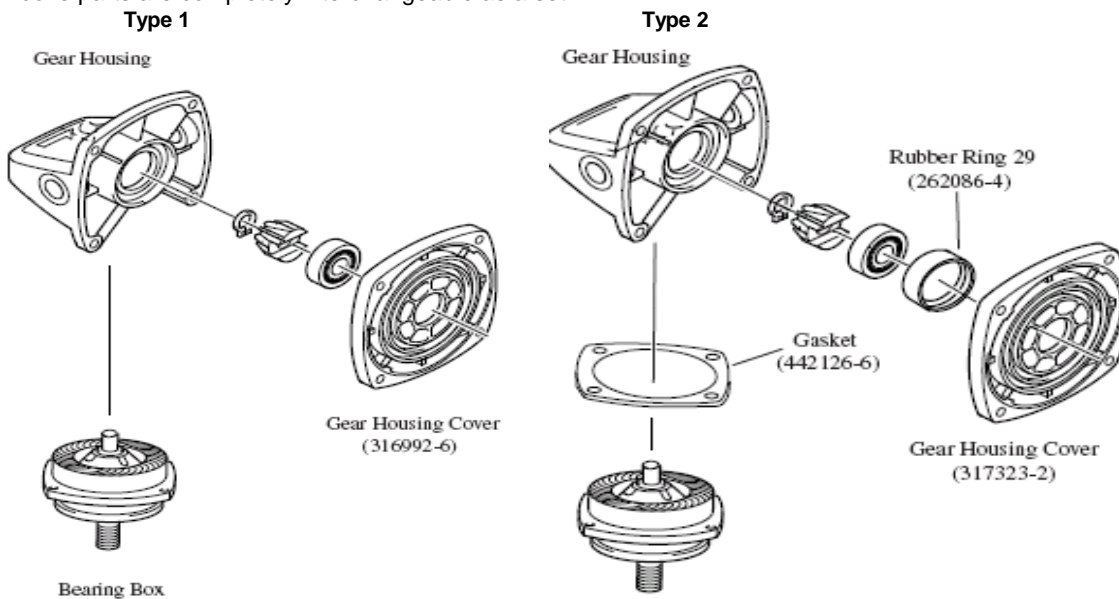

3. Changes on Switch, Handle set, etc. (For 9016DB Only)

Item No.	Description	Type 1	Type 2
15	Handle Set	183010-3	183274-9
24	Switch	651128-3	651166-5
43	Switch Lever Com	-----	163434-9
44	Switch Base	-----	417313-6
100	Screw	652014-1	652039-5
101	Terminal	654002-4	654037-5

Above parts are completely interchangeable as a set.

SERVICE CHANGES

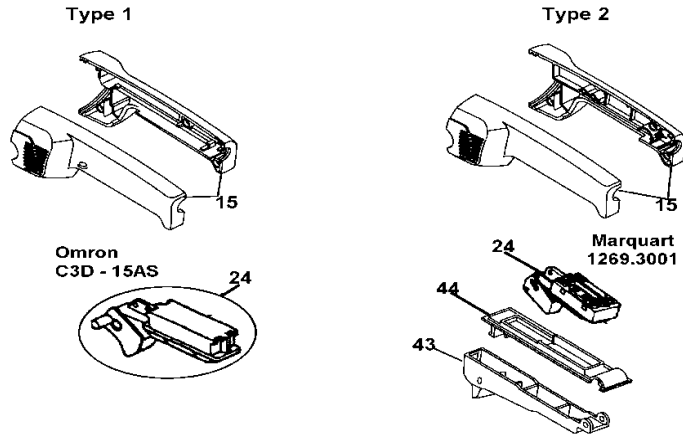

4. Changes on Field Assy and Motor Housing Com.

Item No.	Description	Type 1	Type 2
16	Field		522846-9
18	Motor Housing	159996-3 (N/L/A)	183159-9
	Serial No. 9016DB	~ 5681E	5682E ~
	9016DBZ has Type2 from initial production		

Above parts are completely interchangeable as a set.

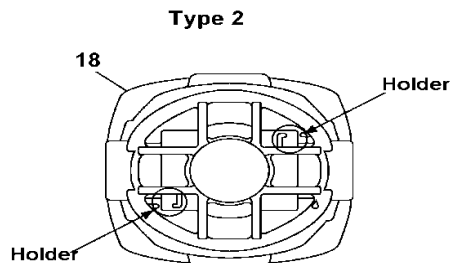
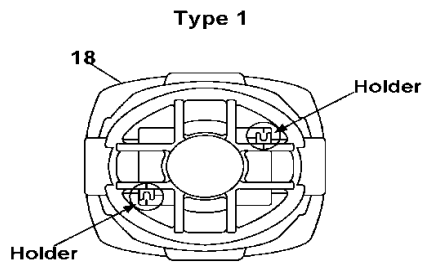
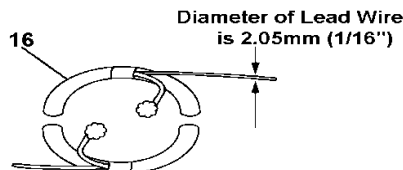
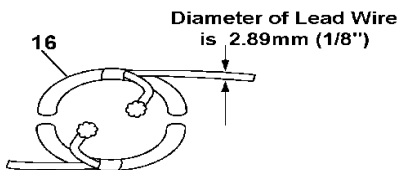

Holders on Item 18 have been modified so that the thinner lead wires can be held more firmly